

**UNIVERSITY COLLEGE TATI (UC TATI)****FINAL EXAMINATION QUESTION BOOKLET**

COURSE CODE	: BET 1013
COURSE	: CIRCUIT THEORY
SEMESTER/SESSION	: 2-2023/2024
DURATION	: 3 HOURS

**Instructions:**

1. This booklet contains **4** questions. Answer **ALL** questions.
2. All answers should be written in answer booklet.
3. Write legibly and draw sketches wherever required.
4. If in doubt, raise your hands and ask the invigilator.

**DO NOT OPEN THIS BOOKLET UNTIL YOU ARE TOLD TO DO SO**

**THIS BOOKLET CONTAINS 7 PRINTED PAGES INCLUDING COVER PAGE**

**QUESTION 1**

a) Answer the following question:

- i. Describe the concept of electrical shock. (3 marks)
- ii. Describe **four (4)** laboratory safety rules for students. (4 marks)

b) Figure 1 shows a resistor with four bands. The color code for each band is given in Table 1. Identify:

- i. The resistance value. (1 mark)
- ii. The percent of tolerance. (1 mark)
- iii. The maximum value the resistor can tolerate. (2 marks)
- iv. The minimum value the resistor can tolerate. (1 mark)
- v. The condition of a resistor when the power rating is less than maximum power in a circuit. (2 marks)

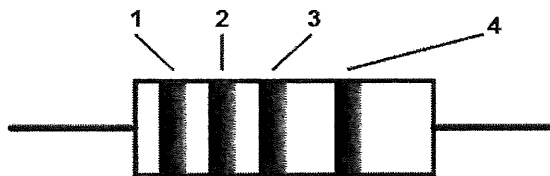

**Figure 1**

**Table 1**

Band	Color
1	Green
2	Blue
3	Violet
4	Silver

- c) Determine the total capacitance,  $C_T$  of the circuit in Figure 2. Show all calculation.

(7 marks)

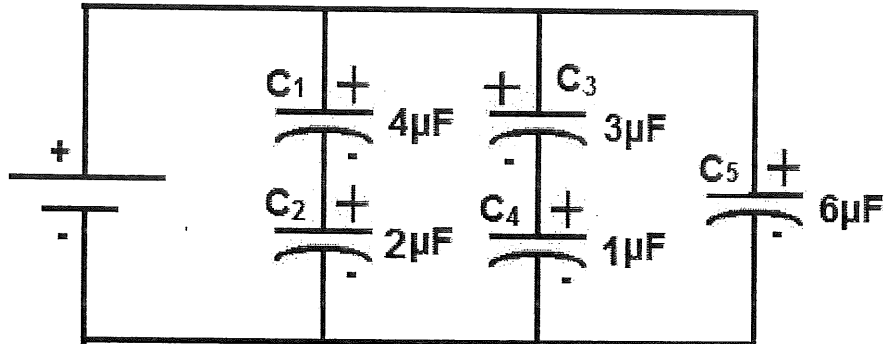

Figure 2

- d) Analyze the circuit in Figure 3 under DC condition:

- i. The current,  $i_L$ . (4 marks)
- ii. The energy stored in inductor,  $W_L$ . (3 marks)

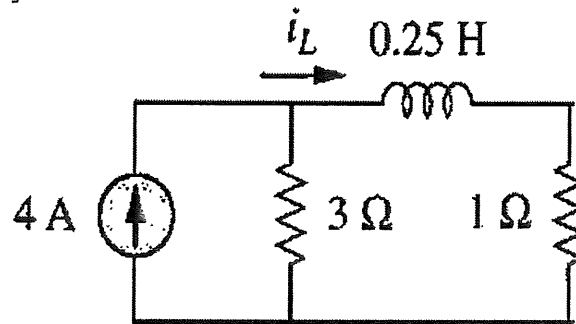
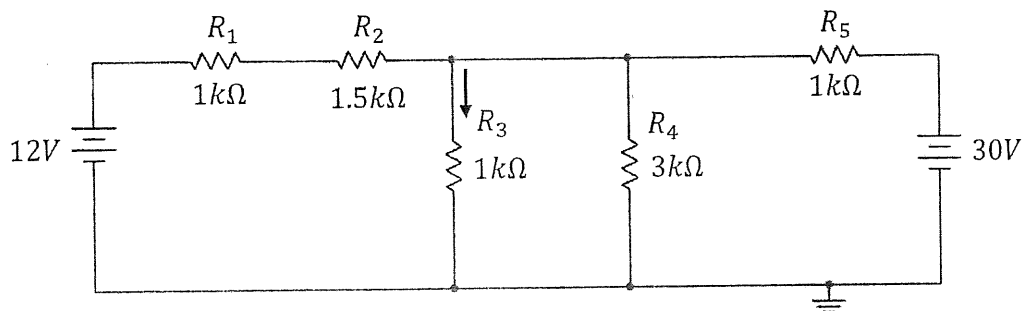

Figure 3

**QUESTION 2**

a) Answer the following questions:

- i. Describe the concept of source transformation. (4 marks)
- ii. Analyze current,  $I$  at resistor,  $R_3$  in Figure 4 by using source transformation. (11 marks)



**Figure 4**

b) Referring to the circuit in Figure 5:

- i. State the voltage value at reference node. (1 mark)
- ii. State the Ohm's Law that used in nodal analysis. (1 mark)
- iii. Without any calculation, describe the expected current through resistor  $8\Omega$  and  $10\Omega$ . Give the reason. (2 marks)
- iv. Analyze the circuit to obtain voltage  $V_1$  and  $V_2$  using nodal analysis. (10 marks)

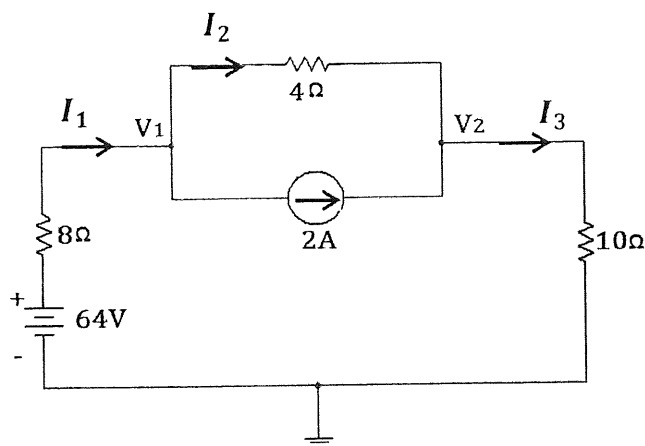

**Figure 5**

## QUESTION 3

a) Given a sinusoid,

$$v(t) = 28 \sin(100t + 10^\circ) \text{ V}$$

Identify for each:

- i. Amplitude,  $v_m$  (1 mark)
  - ii. Phase,  $\phi$  (1 mark)
  - iii. Angular frequency,  $\omega$  (1 mark)
  - iv. Frequency,  $f$  (1 mark)
  - v. Period,  $T$  (1 mark)
  - vi. Phasor,  $V$  (2 marks)
- b) A series-connected load draws a current  $i(t) = 6 \cos(100\pi t + 10^\circ)$  A when the applied voltage is  $v(t) = 150 \cos(100\pi t - 20^\circ)$  V. Answer the following question:
- i. Calculate the apparent power,  $S$  of the load. (4 marks)
  - ii. Calculate the power factor,  $pf$  of the load. (2 marks)
  - iii. Describe the power factor based on your answer in b) (ii). (2 marks)
- c) Determine the input impedance,  $Z_{in}$  of the circuit in Figure 6 at  $\omega = 10 \text{ rad/s}$ .

(7 marks)

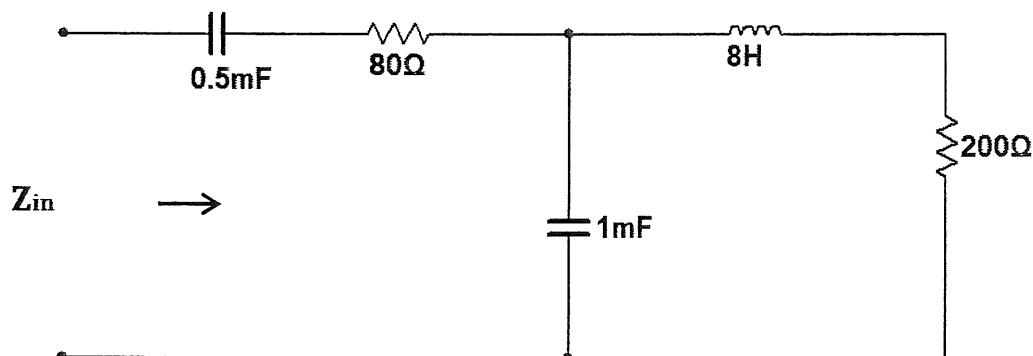

Figure 6

## QUESTION 4

a) Describe the following terms:

- i. Electric power transmission. (3 marks)
- ii. Electric power distribution. (3 marks)

b) Answer the following questions:

- i. Differentiate **two (2)** comparison of series and parallel resonance. (4 marks)
- ii. Describe **three (3)** parameter of resonance circuit. (3 marks)

c) A Y-connected supplies is connected to Y-connected loads as shown in Figure 7. Analyze impedance and current in the given three phase system.

- i. Impedance,  $Z_Y$  (2 marks)
- ii. Current,  $I_a$  (2 marks)
- iii. Current,  $I_b$  (2 marks)
- iv. Current,  $I_c$  (2 marks)

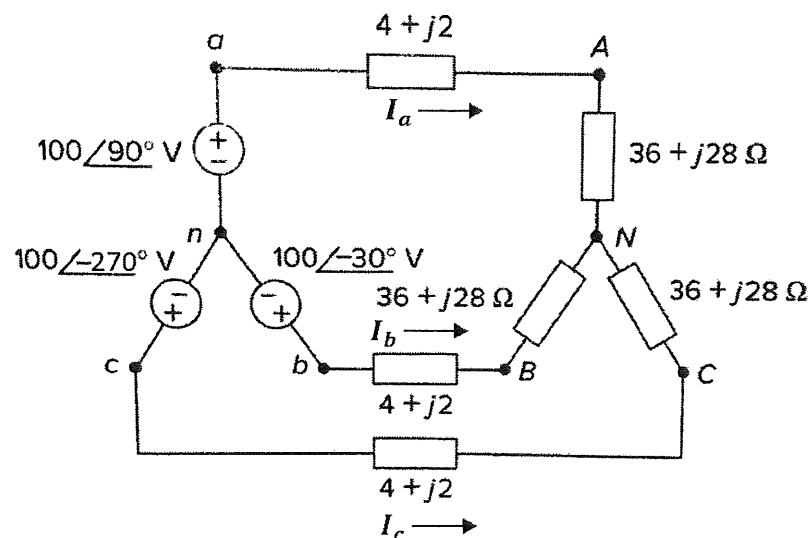

Figure 7

-----End of question-----

CIRCUIT THEORY (BET 1013)

TABLE OF FORMULAS

AC Circuit				
$v(t) = V_m \cos(\omega t + \varphi)$		$V = V_m \angle \varphi$	$Z = R$	$V = IR$
$i(t) = I_m \cos(\omega t + \varphi)$		$I = I_m \angle \varphi$	$Z = \frac{1}{j\omega C}$	$V = \frac{I}{j\omega C}$
$z = x + jy$	$\omega = 2\pi f$	$z = r \angle \varphi$	$Z = j\omega L$	$V = j\omega LI$
$-\sin(A) = \cos(A + 90^\circ)$		$\sin(A) = \cos(A - 90^\circ)$		$Y = \frac{1}{Z_{in}}$
$S = V_{rms} I_{rms}$		$pf = \frac{P}{S} = \cos(\theta_v - \theta_i)$		
$-r \angle \varphi = r \cos(\omega t + \varphi \pm 180)$				
Three Phase Circuit				
<b>Y – Y Connection</b>	$I_a = \frac{V_{an}}{Z_Y}$		$V_{an} = V_P \angle 0^\circ V$ $V_{bn} = V_P \angle -120^\circ V$ $V_{cn} = V_P \angle -240^\circ V$ $Z_1 = Z_2 = Z_3 = Z_Y$	
	$I_b = \frac{V_{bn}}{Z_Y}$			
	$I_c = \frac{V_{cn}}{Z_Y}$			
<b>Δ – Δ Connection</b>	$I_{AB} = \frac{V_{ab}}{Z_\Delta}$		$V_{ab} = V_P \angle 0^\circ V$ $V_{bc} = V_P \angle -120^\circ V$ $V_{ca} = V_P \angle -240^\circ V$ $Z_a = Z_b = Z_c = Z_\Delta$	
	$I_{BC} = \frac{V_{bc}}{Z_\Delta}$			
	$I_{CA} = \frac{V_{ca}}{Z_\Delta}$			
	$I_a = I_{AB} - I_{CA}$			
	$I_b = I_{BC} - I_{AB}$			
	$I_c = I_{CA} - I_{BC}$			

